

Oct. 20, 1953

R. HELL  
RECORDING APPARATUS FOR THE RECEPTION  
OF MESSAGE CHARACTERS  
Filed June 8, 1950

2,656,240

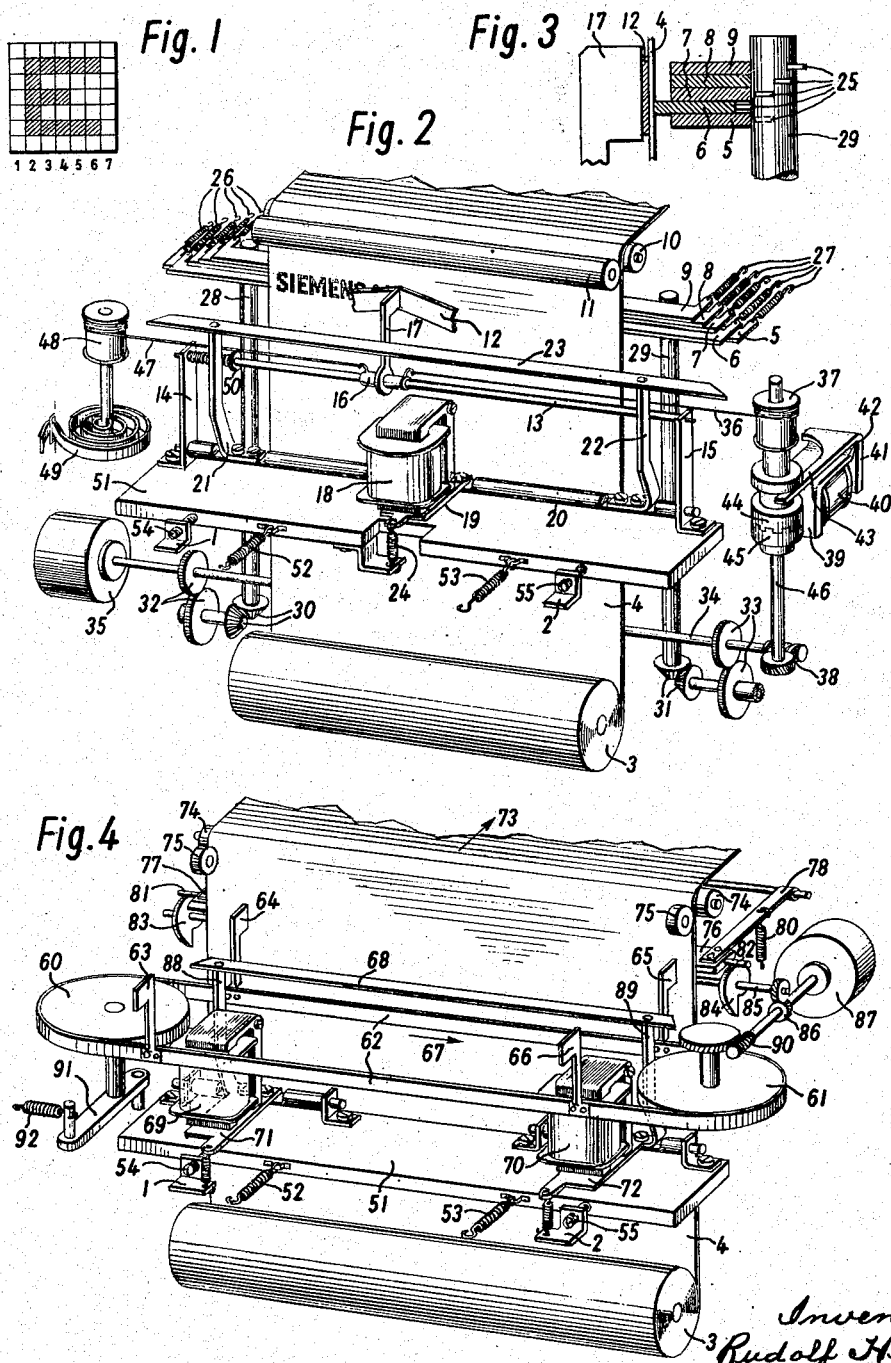

Inventor:  
Rudolf Hell  
By c.w. jones  
Attorney

# UNITED STATES PATENT OFFICE

2,656,240

## RECORDING APPARATUS FOR THE RECEP- TION OF MESSAGE CHARACTERS

Rudolf Hell, Kiel-Dietrichsdorf, Germany, as-  
signor to Siemens & Halske, Aktiengesellschaft,  
Berlin-Siemensstadt and Munich, Germany, a  
German corporation

Application June 8, 1950, Serial No. 166,805  
In Germany December 20, 1948

17 Claims. (Cl. 346—35)

1

My invention relates to recorders, generally of the facsimile type, for translating a sequence of received scanning pulses into directly recorded message characters.

Such facsimile recorders operate on a scanning principle which involves resolving the "picture" area of each character into separate picture elements in the manner elucidated in Fig. 1 of the drawing by the example of the letter "E." As shown, the picture area of the character is broken up, for instance, into seven scanning lines or strips 1 to 7 extending vertically across the area. The first scanning line is vacant. The second line traverses the first one of the vertical strips of the character and requires five pulses corresponding to the five area elements occupied in this line by the character. The following scanning lines 3 to 6 involve three or two pulses corresponding to the number of area elements occupied by the character in these respective lines. The seventh scanning line is again free of occupied elements.

The transmitter has a usually mechanical apparatus which, for instance, upon actuation of the letter key "E" sequentially issues the pulses corresponding to the scanning lines 1 to 7. In a similar manner, the other letters or characters are broken up into lines of picture elements. There are also transmitting apparatus in which the pulse emission is controlled not by a keyboard, but by a perforated five-unit code tape as known for teletypewriters.

The above described known method of transmitting message characters is suitable for tape recorders as well as page recorders. A known design of page printing apparatus has a revolving drum equipped with ridges that extend axially along the drum surface and have a mutual spacing corresponding to the length of the scanning lines, i. e., to the height of the message characters. The recording sheet passes around the drum. While the drum is revolving at a peripheral speed corresponding to the speed at which the individual vertical scanning lines of the character picture areas are scanned in the transmitter, the paper sheet is advanced at a much slower speed either continuously or stepwise after recording a line of characters. An inking ribbon or other coloring means is pressed against the sheet surface in the rhythm of the received pulses by means of a magnet system travelling along the drum, thus printing the characters to be recorded.

In practice, such recorders still present considerable problems. In page recorders of this

2

type, where the slow or incrementally advancing paper sheet passes around a fast-revolving backing drum, it was found necessary to choose a relatively large drum diameter. This results in an undesirably large distance between the backing drum and the paper feed devices. If a message is to be cut off immediately after its reception, the sheet must be advanced an amount at least equal to the just mentioned distance so that much paper is wasted and a more frequent replacement required. Furthermore, the magnet system must be reset to the starting position after each scanning of a line of characters. Due to the relatively large mass of the magnet systems in the known recorders and the shortness of the available time, the resetting demands a considerable amount of structural means and also a special line-change signal pulse.

Referring to recorders for the reception of characters according to the above described or similar methods, it is an object of the invention to provide a recorder design and performance that, as regards one or several of the above mentioned aspects, is greatly improved over those heretofore available. More specifically, the invention aims at reducing the spacing between the recording place and the paper feed means. Still another object of the invention is to minimize the space requirements of the means contacted by the back of the paper sheet at the printing place. It is also an object of the invention to devise a page recorder readily suitable for making several copies.

Referring to facsimile page-printing recorders of the general type above mentioned, and according to a feature of my invention, the paper backing device, heretofore consisting of a ridged or fluted drum, has one or several oscillatory bars which contact the paper behind the printing hammer at a point displaceable across the character area by an upward or transverse shifting movement imparted to the bars by a reciprocating drive such as a cam mechanism. This affords a considerable reduction in the space requirements of the backing device and also results in a greatly reduced distance between the printing place and the paper feed means.

According to another feature of the invention, the necessity of resetting the printing hammer is eliminated by providing a unidirectionally rotating endless band or the like in front of the record sheet and mounting several hammer members on the band with a mutual spacing sufficient to place only one of the hammer members at a time into printing relation to the sheet.

These and other objects, features and advantages of my invention will be apparent from the following in conjunction with the drawings, in which:

Fig. 1, already discussed, elucidates the known scanning or integrating principle also applicable for recorders according to the invention;

Fig. 2 shows schematically and in perspective an embodiment of a page recorder according to the invention having a stationary magnet system, a translatable printing hammer controlled by the magnet system and a backing bar device consisting of five bars;

Fig. 3 shows on a larger scale the side view of a detail of the recorder according to Fig. 2;

Fig. 4 shows schematically and in perspective another embodiment of a page recorder according to the invention having continuously rotating printing hammers and a backing device with only one backing bar.

In the interest of lucid illustration, the stationary support structure of the recorder shown in Fig. 2 is represented only by some appertaining or rigidly attached bracket members 1 and 2. Mounted on the support structure is a paper feed device from whose drum 3 the record paper 4 passes over a stack of backing bars 5, 6, 7, 8, 9 and then between guide rollers 10 and 11.

Located in front of the paper is an inking ribbon 12, partially shown, whose feed device is not illustrated because it may be similar to that customary for typewriters. A guide rail 13 extends across the paper surface and is mounted on brackets 14 and 15. Slidably mounted on rail 13 is a sleeve 16 which carries a printing hammer 17 serving as an intermediate pressure-transmitting member between the record surface and the actuating magnet system. The magnet system 18 has a movable armature 19 mounted on a shaft 20 which is revolvably journaled in the brackets 14 and 15 and equipped with arms 21 and 22 which carry a pressing bar 23 in front of the hammer 17 and along its path of displacement. The bar 23, when actuated by the magnet 18 against the tension of the spring 24 in the rhythm of the signals received by the magnet, hits against the hammer member 17 and forces it against the record paper, thus causing the ribbon 12 to produce a mark on the paper surface.

A stack of pressure bars comprising five individual bars 5 to 9 is disposed behind the paper 4 and extends over the entire width of the sheet. The individual bars 5 to 9 of the stack are disposed one above the other in close relation to one another, but are out of contact with the paper 4 when in their respective rest positions. The total height of the stack is in accordance with the length of a picture-scanning line and, of course, with the maximum height of the characters to be written.

One of the bars at a time is moved forward against the record paper 4 so that the bars engage the paper in a given sequence, each bar being returned to the start position as soon as the next bar is in contact with the sheet. After the last bar having thus been operated in sequence to the others, the first bar will begin the next cycle. In this manner, the line contact of the backing device with the paper sheet 4 travels always in the paper feed direction (or opposite thereto) with a resultant backing effect similar to that obtained with fluted backing drums, while occupying considerably less space than required by such drums. The means for securing this performance will be described presently.

All five bars are individually pulled by springs, schematically shown at 26 and 27 in a direction away from the paper and normally rest against two control shafts 28 and 29. The two shafts are driven by respective gear pairs 30, 31, 32, 33, from a shaft 34 which is coupled with a motor 35 and revolves at such a speed that each complete revolution of shafts 28 and 29 corresponds to the period of a single scanning line. As apparent from Fig. 3, five cam members schematically shown at 25 are disposed on each of the shafts 28 and 29. The cams of each shaft are helically displaced relative to the axis of the control shaft and with a uniform angular spacing.

In Figs. 2 and 3 the mechanism is shown at a moment in which one of the cams 25 presses the ledge 6 in opposition to its spring bias against the record sheet 4. When, within this time interval, the appertaining printing hammer 17 is forced by the magnet 18 against the other side of the sheet 4, the vertical printing edge of the hammer head forces the inking ribbon 12 against the sheet and against the ledge 6 at a small pressure area which corresponds to one of the picture elements of the one line then being scanned in the transmitter. After a small angular rotation of the control shafts 28 and 29, the next upper of the cams 25 moves toward the ledge 7 and forces this ledge forward into engagement with the sheet 4, while the ledge 6 is withdrawn. Then, if the printing hammer 17 is active, an adjacent elemental area of the same scanning line is marked. Due to the helical displacement of the cams, the ledges of the backing device are thus sequentially actuated, the lowermost becoming active while the uppermost ledge is being withdrawn. It will be recognized that the operation of this backing device, as regards the resulting printing performance, is similar to that of a revolving ridged drum, but it has the advantage that the movement of the ledges is only toward and away from the paper without any tendency to tear the paper sheet or to move it in an undesired way.

The printing hammer 17 with its guiding sleeve 16 is continuously moved from a starting position at the left toward the right in synchronism with the advancing speed of the scanning in the transmitter. This movement is imparted to the sleeve 16 by a rope 35 wound up on a drum 37, which is driven from the shaft 34 of the motor 35 through a worm gear 38 and a magnetic coupling device 39.

Thus the movement of the sleeve 16 continues until the coil 40 of the magnetic coupling device 39 is energized. Then the armature 41, movably mounted on an edge 42, is attracted and its arm 43 raises the upper coupling part 44 which is joined with the drum 37 and which is axially displaceable on shaft 46. Thus the upper coupling part 44 and the drum 37 are disengaged from the lower coupling part 45 mounted rigidly on the driven shaft 46, and the drum 37 is permitted to rotate backwards. This is done by a pull rope 47 connecting the sleeve 16 with a rewind-drum 48. This drum is actuated by a return spring 49 for rapidly returning the sleeve 16 and hammer 17 to the starting position. An elastically movable stop member 50 mounted on the rail 13 dampens the impact and is displaced toward the left when the hammer assembly reaches the starting position. This displacement of member 50 serves to actuate a control contact (not shown). The control circuit of coupling magnet 40 is energized by the reception of

5

a special reset signal, for instance a continuous signal or a given frequency modulated signal, and becomes deenergized under control by the just-mentioned contact of member 50 when the hammer assembly is returned to its start position. This operation can be obtained by various known circuit combinations of relays and switches whose particular design is not essential to the invention proper.

However, the drum 37 becomes coupled with the motor 35 only when thereafter the coupling members 44 and 45 reach a correct phase position relative to each other. Consequently, after the resetting of the printing hammer 17, its next advancing movement will start only after a period of time determined by the angular displacement of the coupling members 44 and 45.

It is, of course, also possible to control the return movement of the hammer assembly only mechanically and to replace the illustrated coupling by a simple friction coupling with electric or mechanical releasing means.

In the illustrated example, the position of the pressing bar 23 relative to the backing bars 5 to 9 can be accurately adjusted. For this purpose, the entire printing system is mounted on a displaceable plate 51 which is biased by springs 52 and 53 toward the stationary brackets 1 and 2. Spacing screws 54 and 55 pass through corresponding openings of brackets 1 and 2 so that the distance between plate 51 and brackets 1, 2 and hence the distance between the printing system and the backing ledge device can be varied by turning the adjusting screws 54 and 55. For facilitating an accurate adjustment, the spacing screws 54 and 55 may be preferably equipped with large knurled heads (not shown).

If the use of a special reset signal is undesired, the release of the hammer return movement may also occur automatically after completing the printing of a line of characters, for instance, by locating a limit switch with a control member similar to member 59 at the right hand end of the hammer path.

If the receiving recorder is to be intermittently synchronized with the transmitter as regards the printing periods for complete lines of characters, that is, if the recording of each line of characters is to begin at a given moment dictated by the transmitter, the arrangement is designed in such a manner that after each release of the hammer return movement a predetermined period of time will elapse before the printing hammer 17 is again advanced across the sheet. For instance, it is advantageous to make this predetermined period about equal to that required for the transmission of a complete, individual message character.

In the illustrated recorder, the record sheet may be fed in continuous motion at such a speed that gaps will normally occur between successive lines of characters. Then, the spacing between the lines of print will become smaller than normal when only a part of a character line is printed and the printing of the next line will begin immediately. To avoid such an uneven spacing, the paper sheet may be fed intermittently in steps corresponding to the individual character lines, the paper feed movement being released by the resetting of the sleeve 16 and the printing hammer 17. In this case, the paper travel for each step of feed movement is equal to or larger than the height of a character depending upon the desired spacing between the lines of characters.

6

In recorders according to the invention, the reciprocating printing assembly can be replaced, as mentioned, by a unidirectional-motion device with an endless band or the like rotating in front of the record paper and carrying several sequentially operable hammer members. The recorder shown in Fig. 4 represents an embodiment of this type in connection with another form of the backing ledge device.

In the recorder according to Fig. 4, two sheaves 60 and 61, one of which is driven, are rotatably mounted in front of the paper sheet 4 and surrounded by an endless steel tape 62 which carries four printing hammers 63, 64, 65 and 66. The edge-like hammer faces engageable with the sheet 4 have a length at least equal to the height of the lines of characters to be printed.

The tape 62 rotates in the direction of the arrow 67 at a speed corresponding to the advancing speed of the scanning performance in the transmitter. During this travel, only one of the four printing hammers at a time is located in front of the paper. A pressing bar 68 extends across the paper sheet 4 within the area surrounded by the band 62. Two magnets 69 and 70 have respective armatures 71 and 72 connected with the bar 68 to force it toward the adjacent portion of the band 62, thus pressing the one hammer engageable with the bar against the paper surface. At this moment, in cooperation with the backing device still to be described, a mark is produced on the paper with the aid of an inking ribbon (not shown). The magnets 69 and 70 are energized in the rhythm of the received signals so that the individual characters are printed in the integrating manner explained previously.

The distance between the hammers 63, 64, 65 and 66 along tape 62 is preferably equal to the length of a line of characters so that when a line is completed, the printing of the next line is immediately started. However, if it is desired to obtain some overlapping so that, when the last few characters of a line are being printed, the same characters are simultaneously printed by the next hammer at the beginning of the next line, then the distance between the hammers must be made somewhat shorter than the length of the line. It will be recognized that an endless-band device with several sequentially operating hammers does not require resetting so that a reset signal or limit switch control means are not needed. However, a reset signal may be used, if desired, for rapidly advancing the band at higher than normal speed to the start position of the next operative hammer after recording less than a full line of characters.

For coloring the record surface under control by the printing hammer, a carbon paper may be used instead of the above mentioned inking ribbon. The carbon paper may be placed between the record sheet and hammer, or between record sheet and backing device. When providing an inking ribbon, an automatic reversal of the ribbon feed may be provided similar to that customary for typewriters. While the ribbon feed may be continuous, it is also possible to provide a feed control device which moves the ribbon in predetermined intervals of time and in steps corresponding to the width of the record sheet so that the inking ribbon is stationary during the printing of each line of characters. For obtaining a visible print, the coloring may also be effected by an endless coloring sheet whose width corresponds substantially to that of the record

sheet and which extends along the back of the sheet. With a transparent record paper, this device will produce the print on the back surface of the sheet to be read from the front of the sheet.

It is also possible to use beneath the record sheet a copyable inking ribbon or coloring sheet in addition to an ordinary inking ribbon in front of the record sheet. Then two prints are obtained at both sheet surfaces, of which the one appearing on the back surface is mirror-reversed and can be used for printing additional copies in accordance with a known reproduction method. Several copies may also be produced by inserting several record sheets with intermediate sheets of carbon paper or using several record sheets whose back surfaces are carbonized.

The feed movement of the record paper 4 in the apparatus according to Fig. 4 may be continuous in the direction of the arrow 73. According to another feature of the invention, the sheet 4 may be guided in a slanted direction relative to the tape 62, the angle of slant being such that, with a continuous paper feed movement, the difference in height between the left and right ends of one and the same line of characters is just compensated by the slanted arrangement. To this end, the sheet at the left side is guided higher than at the right side by an amount equal to the height of a character plus the line spacing. Another possibility consists in applying a straight direction of paper feed and placing the line printing device in a slanted direction to the paper.

The record sheet 4 moves upwards between rollers 74 and 75. The backing device behind the sheet may be the same as in Fig. 2 or, as illustrated, it may have only one bar member 76 edgewise contacting the paper across the paper width. The bar member 76 is mounted on spring strips 77 and 78 which are drawn downwards by springs 80. Two axially projecting dog pins 81 and 82 of bar 76 are pressed against respective control cams 83 and 84 mounted on a cam shaft 85. During the operation of the recorder, the revolving cam shaft 85 causes the cams to lift the bar 76 at a relatively low speed, while the springs take care of rapidly returning the bar to a lowermost position determined by the bottoms of the cam contours. The upward movement of the backing bar 76 has a uniform speed corresponding to the line-scanning speed of the transmitter. In the illustrated embodiment, the backing bar 76 moves about the pivot points of the strips 78 and 79. However, a more accurate parallel motion of the backing ledge can be provided, for instance, by arranging a pair of spring strips at each axial side of the bar.

The cam shaft 85 is driven through gears 86 from a motor 87 to perform one full revolution within the period of one scanning line. For instance, when the transmission corresponds to the scanning method explained in the foregoing with reference to Fig. 1, seven revolutions of the cam shaft 85 occur during the period of time required for the seven vertical scanning lines to cover the entire picture area of a single character to be transmitted. Suitable phase adjusting means (not shown) are provided to secure the proper phase relation of the movements of ledge 76 relative to the sequence of scanning signals received by the recorder.

For printing the characters on the sheet 4, the embodiment of Fig. 4 is equipped with two stationary magnets 69 and 70 whose respective

movable armatures 71 and 72 act through respective pressure rods 88 and 89 on the pressure bar 68 which, like those of the preceding embodiments, extend in the sequence direction of the characters to be printed across the front side of the record paper. The connection between the magnet armatures 71 and 72, the pressure rods 88 and 89 and the pressure bar 68 may be effected through movable joints so that the two magnet systems are not rigidly coupled with each other. This arrangement is desirable to permit both magnets to develop their full operating power.

The above mentioned motor 87 may be used, as shown, also for driving the endless steel tape or chain 62 carrying the printing hammers 63 to 66. Sheave 61 is rotated by the motor shaft through a worm gear 90. The other sheave 60 is mounted on the pivoted arm 91 of a tensioning device biased by a spring 92 to maintain the endless tape 62 under proper tension.

As is apparent from the illustrated and described embodiments, my invention permits of various and diversified modifications, and it will be readily understood by those skilled in the art, upon a study of this disclosure, that various alterations and modifications other than those specifically referred to can be made without foregoing the objects or advantages of the invention and within the scope of its essential features set forth in the claims annexed hereto.

I claim:

1. Facsimile page printing apparatus, comprising paper feed means, a paper backing device containing reciprocable bar means having line contact with the paper transverse to the paper feed direction and over the entire length of the lines of characters to be printed, cyclically operating drive means connected with said bar means to impart reciprocating motion thereto for periodically moving said line contact in said direction a distance corresponding approximately to the maximum height of the characters to be printed, hammer-like printing means movable across said paper feed direction at the paper side away from said backing device and having an elongated hammer face extending in said paper feed direction over said height, signal-responsive means, and means connecting said signal-responsive means with said printing means for actuating said printing means toward the paper to produce marks on the paper at the crossing points of said printing means with said bar means.

2. Facsimile page printing apparatus, comprising means for moving a recording sheet, oscillating sheet backing means extending over the width of the sheet across the direction of sheet movement and having with the sheet a line engagement of oscillatory movement parallel to said direction over a range substantially equal to the maximum height of the characters to be printed, an intermediate member displaceable transverse to said direction at the sheet side opposite said backing means, said member having an elongated hammer face extending in said direction over said range, and movable control means responsive to received signals and engageable with said member for moving said member toward said backing means.

3. Facsimile page printing apparatus, comprising paper feed means, a paper backing device having oscillatory bar means extending over the width of the paper transverse to the paper feed direction and being edgewise engageable with the paper to form a line contact therewith,

periodic drive means connected with said bar means for reciprocating said line contact parallel to said direction a distance substantially equal to the maximum height of the characters to be pivoted, an intermediate member displaceable transverse to said direction at the sheet side opposite said backing device, said member having an elongated hammer face facing said backing device and extending in said direction over said distance, and control means responsive to received signals and engageable with said member for applying printing pressure thereto.

4. Facsimile page printing apparatus comprising paper feed means, a paper backing device having oscillatory bar means extending over the width of the paper across the paper feed direction and having with the paper a line contact reciprocable parallel to said direction a distance substantially corresponding substantially to the maximum height of the line of characters to be printed, oscillatory-motion drive means connected with said bar means, a signal-responsive magnet having an armature, a hammer member displaceable transverse to said direction and movable toward the paper at the paper side opposite said means, said hammer member having an elongated hammer face extending in said paper feed direction over said distance, drive means of substantially constant speed connected with said member for displacing said member, a hammer control bar extending along the path of said member and being movable against said member to apply printing pressure thereto, and means connecting said bar with said armature for actuating said bar under control by signals received by said magnet.

5. Facsimile page printing apparatus, comprising paper feed means, backing means having a single bar member extending over the width of the paper transverse the paper feed direction and having a longitudinal edge directed toward the paper, said bar being reciprocable parallel to said direction a distance corresponding to the height of the line of characters to be printed, an intermediate member displaceable transverse to said direction at the sheet side opposite said backing means and having an elongated hammer face extending in said direction over said distance, and movable control means responsive to received signals for moving said member toward said backing means.

6. Apparatus according to claim 5, comprising reciprocating drive means connected with said bar member and having slow forward strokes and fast return strokes, said forward strokes being coincident with respective operating periods of said control means.

7. Apparatus according to claim 5, comprising a drive having a continuously revolvable shaft and a control cam on said shaft, said cam being in engagement with said bar member and shaped to impart to said bar member a slow forward stroke and a fast return stroke.

8. In apparatus according to claim 2, said backing means comprising a stack of bar members extending across the sheet and having respective longitudinal edges facing the sheet, said bar members being individually movable toward the sheet and away therefrom, and reciprocating drive means connected with said bar members for sequentially moving them in a given cycle.

9. In apparatus according to claim 2, said backing means comprising a stack of bar mem-

bers extending across the record sheet and having respective longitudinal edges facing the sheet, said bar members being individually movable toward the sheet, and reciprocating drive means having a revolvable shaft and a group of cam means on said shaft, said cam means being angularly displaced relative to each other and engageable with said respective bar members for sequentially moving them in a given cycle.

10. Facsimile page printing apparatus, comprising paper feed means, oscillatory backing means having a line contact with the paper in a direction transverse to the paper feed and reciprocable transverse to said direction a distance substantially according to the height of the individual lines of characters to be printed, a signal-responsive magnet having an armature, a plurality of printing hammers unidirectionally movable parallel to said direction at the paper side away from said backing means, said hammers being spaced from each other in said direction a distance similar to the length of said lines of characters, each of said hammers having an elongated hammer face transverse to said direction and of a length similar to said height, said hammer faces being located opposite said backing means, a hammer control bar extending across the paper in said direction and being movable toward said hammers to apply printing pressure thereto, and means connecting said armature with said bar for controlling said bar by said magnet.

11. Apparatus according to claim 10, comprising an endless band drive of uniform speed having a band member extending across the paper parallel to said direction, said hammers being mounted on said band member.

12. Facsimile page printing apparatus, comprising paper feed means, oscillatory backing means having a line contact with the paper in a direction transverse to the paper feed and reciprocable transversely to said direction a distance substantially according to the height of the individual lines of characters to be printed, a signal-responsive magnet having an armature, a hammer member displaceable in said direction and movable toward the paper at the paper side away from said backing means, a hammer control bar extending along the displacement path of said member and being movable against said member to apply printing pressure thereto, said bar being connected with said armature to be controlled by said magnet, hammer displacement control means having a constant-speed drive operative in the character printing direction, and reset means having a higher speed than said displacement control means and being operative in the opposite direction, and release means connected with said control means to render said reset means effective before starting the recording of a line of characters.

13. In a recorder according to claim 12, said release means being electric and having a circuit responsive to receipt of a special reset signal.

14. A recorder according to claim 12, comprising a pull rope connecting said hammer member with said drive, and said release means being disposed between said pull rope and said drive to disengage them from each other under control by said release means.

15. In a recorder according to claim 12, said reset means having a return spring connected with said hammer member and biasing it toward a given start position.

16. In a recorder according to claim 12, said release means being connected with said drive for

disconnecting said drive to then permit said reset means to return said hammer member to the start position, and limit contact means controlled by said hammer member in said position to reconnect said drive.

17. A recorder according to claim 12, comprising coupling means disposed between said drive and said hammer member and having two parts connected with said drive and said member respectively and drivingly engageable with each other only in given mutual phase positions whereby said drive becomes effective only after elapse of a given period of time after resetting of said member.

RUDOLF HELL. 15

References Cited in the file of this patent

UNITED STATES PATENTS

Number	Name	Date
2,131,741	Kleinschmide et al. ---	Oct. 4, 1938
2,246,003	Rich -----	June 17, 1941
2,280,613	Avey -----	Apr. 21, 1942
2,298,276	Burcky et al. -----	Oct. 13, 1942

FOREIGN PATENTS

Number	Country	Date
425,883	Great Britain -----	Mar. 22, 1935
812,688	France -----	Feb. 8, 1937